

■ GECKO BATTERY | MOBILE WELDING TRACTOR

The GECKO BATTERY is a battery-powered welding tractor designed to produce continuous butt and fillet welds using MIG/MAG torches.

4-wheel drive system with magnetic traction and a feedback loop provide speed stabilization in all welding positions.

Constant, continuous and repeatable travel speed enables weld bead geometry that is exact to the required specifications, thus reducing costly over welding and substantially decreasing filler metal usage.

Optional accessories make Gecko Battery fit for various applications with carbon steel, stainless steel and aluminum.



18 V DC battery with a capacity of 5.2 Ah provides energy for 6hrs average operation time.



GECKO BATTERY can also be connected to 110-240 V AC mains by means of power supply.

■ Applications:

- Trailer manufacturing
- Truck tanks
- Oil tanks
- Water storage tanks
- Transformers
- Shipyards
- Any application demanding a long, continuous fillet weld

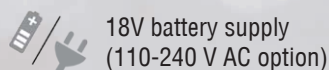

18V battery supply
(110-240 V AC option)



Continuous welding



Dual torch welding



Horizontal speed
0-110 cm/min (0-43.3 in/min)



Dual arc ignition



Min. path convex radius
1000 mm (3.5 ft)



Min. path concave radius
1000 mm (3.5 ft)



Weight 8.6kg (19 lbs)

Versatility of applications including out-of-position use

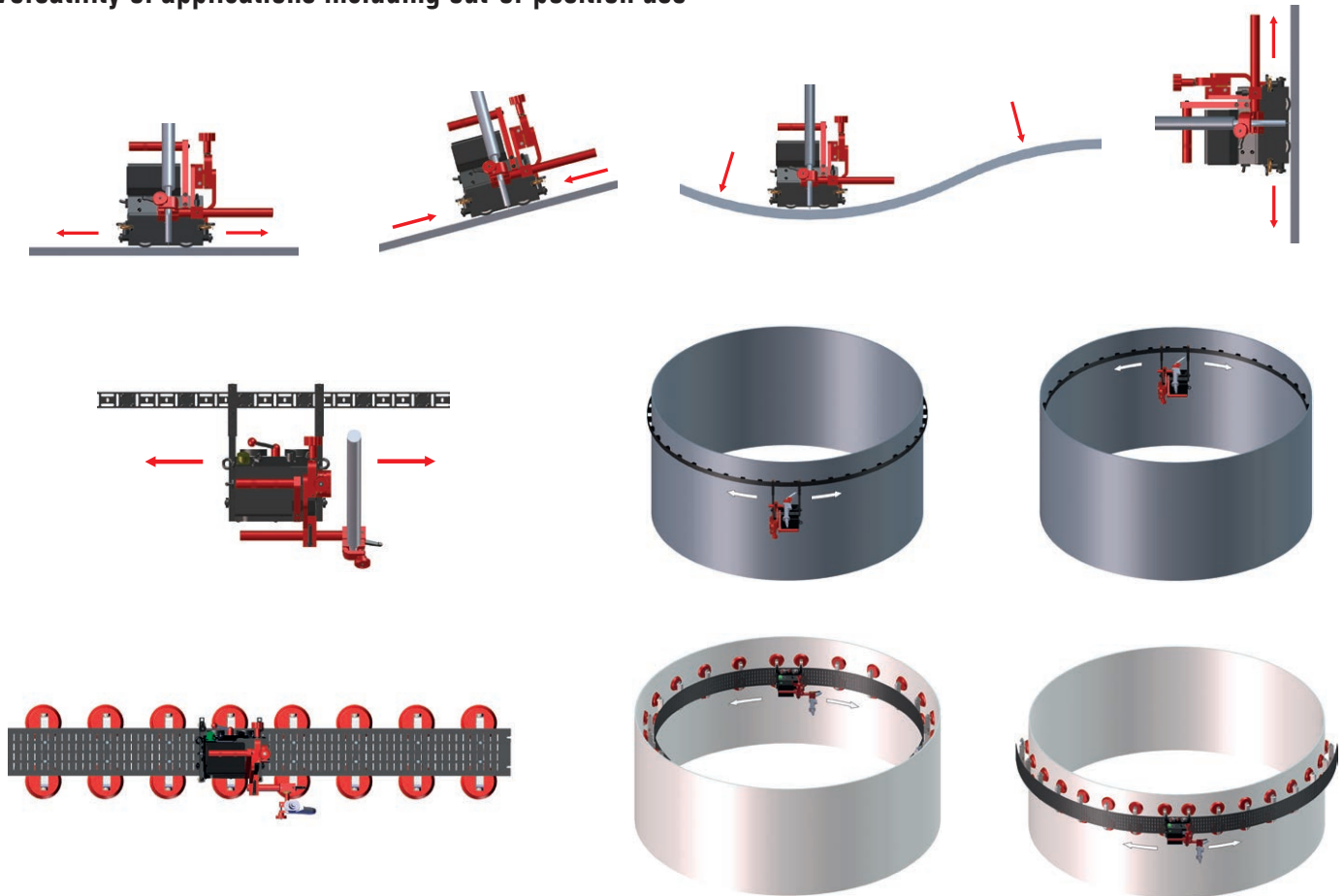

Primary features and benefits of Gecko Battery Welding tractor:

- Compact, lightweight design with durable aluminum cast housing
- Convenient 18 V DC battery supply
- Optional power supply 110-240 V AC 50/60 Hz
- Strong magnetic traction permits out of position use
- Magnet on/off lever permits easy set up and adjustment on work piece
- Maintenance free 4-wheel drive with worm gear reduction
- Heat resistant silicone wheels
- Quick clamping torch holder mechanism for different types of MIG/MAG torches with diameters of 16-22 mm (5/8"-7/8"); optionally up to 35 mm (1-3/8")
- Precise torch adjustment with screw drive cross slide
- Multifunctional LED display - presetting of travel speed, units, error codes information
- Closed loop speed control system stabilizes travel speed to reduce weld defects and costly rework
- Consistent heat input reduces distortion
- Reduced wasted filler metal - eliminates over welding
- Automatic arc on/off system initiates welding with travel, simultaneously
- Capable of carrying and controlling two torches
- Self-guiding roller arms eliminate the need for track
- Multi-surface guiding with user-friendly adjustment of tractor position
- Improves working environment - removes operator from heat and fumes

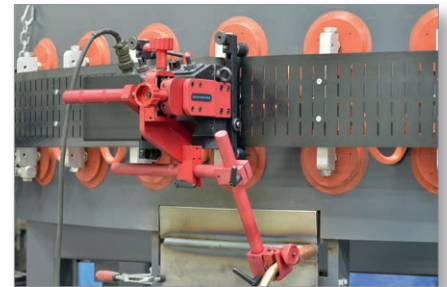

TECHNICAL SPECIFICATIONS GECKO BATTERY	
Voltage	18 V DC, 5.2 Ah
Power	20 W
Welding position (according to EN ISO 6947 and AWS/ASME)	PA / 1F / 1G PB / 2F PC / 2G PD / 4F PE / 4G
Torch diameter	16–22 mm (0.63–0.87"); up to 35mm (1.38") option
Minimum radius of curved workpiece surface	1000 mm (3.5 ft)
Minimum workpiece thickness	4 mm (0.16")
Ground clearance	4 mm (0.16")
Horizontal pulling force	150 N
Cross slide adjustment range	0–35 mm (0–1.38") up-down, left-right
Horizontal speed*	0–110 cm/min (0–43.3 in/min)
Weight	8.6 kg (19 lbs)
Welding settings storage	1 (last used)

* With battery fully charged.

The newest improved guide arms family makes a proper welding tractor positioning even easier.

- 7 different guide types are dedicated to various welding applications and positions
- include a number of fixing grooves for your convenience
- enable simpler, easier and more consistent adjustment of how guide arms stick out
- secure proper tilting of the carriage into a direction of its movement
- maintain a permanent contact with the workpiece
- allow either interval or continuous guide arms adjustment

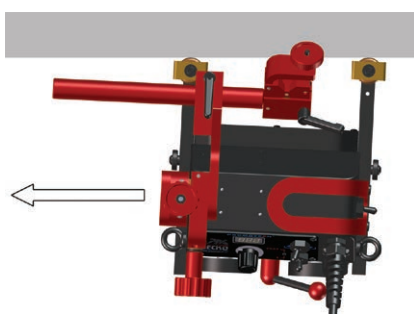

Each new guide arm has got a number of indented grooves only on one side.

All types of guide arms are available in pairs of 2 pcs: right and left.

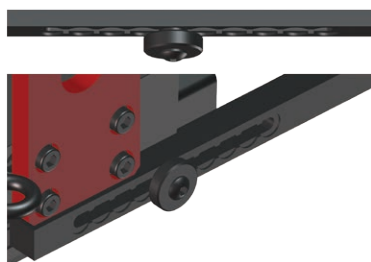
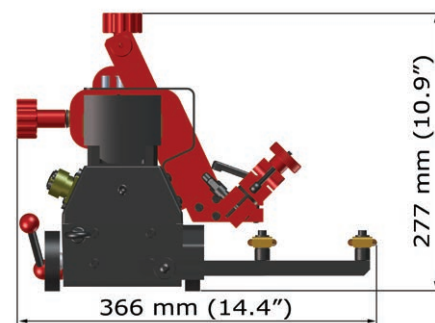

Interval adjustment of a degree how much the guide arms stick out

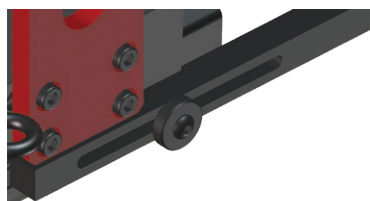

Continuous adjustment of a degree how much the guide arms stick out

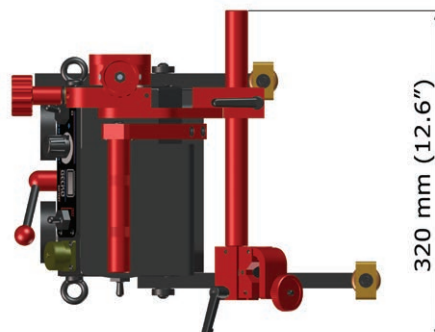

Standard accessories



PRW-0466-67-00-00-0
Standard guide arms (set of 2 pcs)

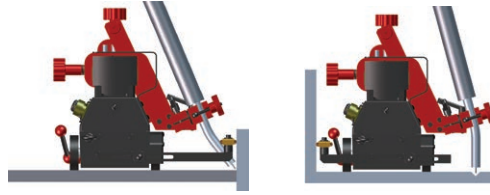

AKM-000086
5.2 Ah Battery



KBL-0466-17-00-00-0
Dual arc ignition cable of 6.5 m (21 ft)



UCW-0466-04-00-00-0 Torch holder long rod clamp assembly

Optional accessories for variety of applications



ZSL-0526-20-00-00-0
Power supply



LDW-000006 (220-240 V, 50/60 Hz)
LDW-000007 (120 V, 60 Hz)
Battery charger



PWD-0466-18-00-00-0 (230 V CEE)
PWD-0466-16-00-00-0 (115 V USA)
PWD-0466-23-00-00-0 (115 V UK)
Power cord 3m (10 ft)



PDT-0526-21-00-00-0
Cable anchor



URZ-000001
Fall arrester device

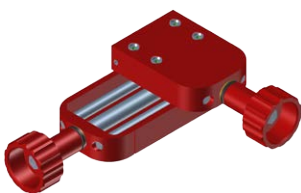

ZSP-0466-46-00-00-1
Extended cross-slide
0-76 mm (0-3") up-down,
0-35 mm (0-1.38") left-right



PRD-0466-43-00-00-0
Torch Extension Arm

WLK-0476-20-01-00-0
Short Rod Clamp



OSL-0466-29-00-00-0
Display shield



ZRZ-0466-19-00-00-0
Torch clamp 22-35 mm



PDT-0466-40-00-00-0
Dual Torch Mount



BLO-0466-44-01-00-0
Magnet blocks (front)
M5x25

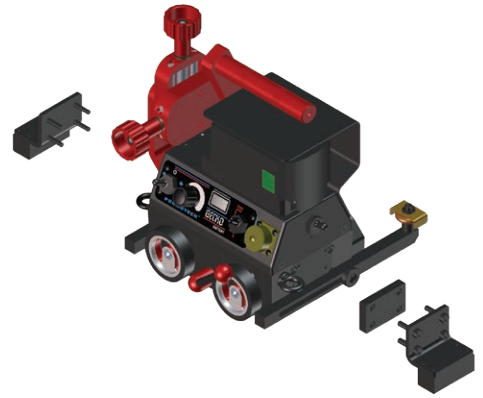

BLO-0466-47-01-00-0
Magnet blocks (front) with
increased power M5x25

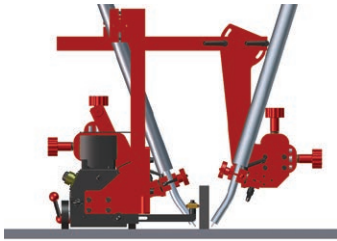

BLO-0466-45-01-00-0
Magnet blocks (back) M6x25
incl. additional spacer plate
required for Gecko Battery only



BLO-0466-48-01-00-0
Magnet blocks (back) with
increased power M6x25

Optional accessories for multi-surface guiding and variety of applications



PRW-0466-65-00-00-1
Low guide arms (set of 2 pcs)

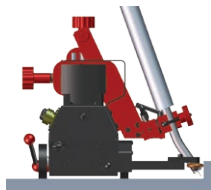

PRW-0466-66-00-00-1
High guide arms (set of 2 pcs)



PRW-0466-41-00-00-1
Edge following guide arms (set of 2 pcs)

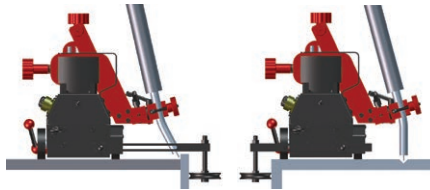

PRW-0466-42-00-00-1
Adjustable guide arms (set of 2 pcs)



PRW-0466-50-02-00-1
Track following guide arms (set of 2 pcs)

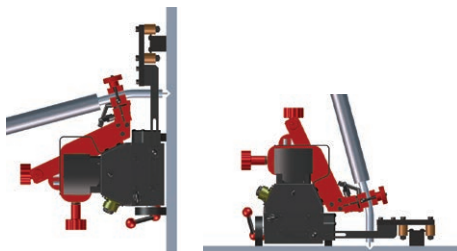

PRW-0466-52-00-00-1
Magnet guide arms (set of 2 pcs)

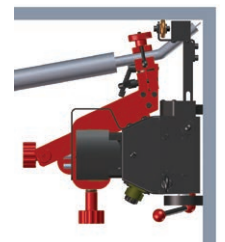

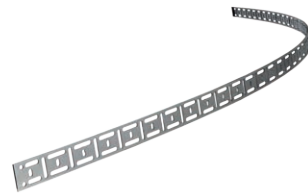

Flexible track length 185cm (6ft) 1pc
Minimum curvature radius of 1.0 m (3.3 ft)
PRW-0466-50-01-01-0



Magnetic block for flexible track
box of 10 pcs
BLO-0466-68-00-00-0



UST-0466-53-00-00-0
Guide adjustment tool to position the
track parallel to the edge

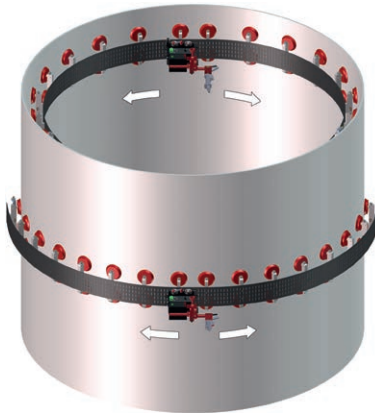
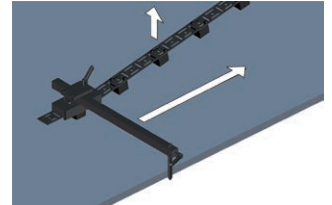

Vacuum units in use on stainless steel
or aluminum tanks

Depending on sort of fixing units in use with flexible trackway, Gecko
Battery welding tractor is suitable for applications with carbon steel,
stainless steel and aluminum.

Flexible trackway length 1.88 m (6.1 ft).
Minimum curvature radius of 1.25 m (4.1 ft)
PRW-0466-71-00-00-0

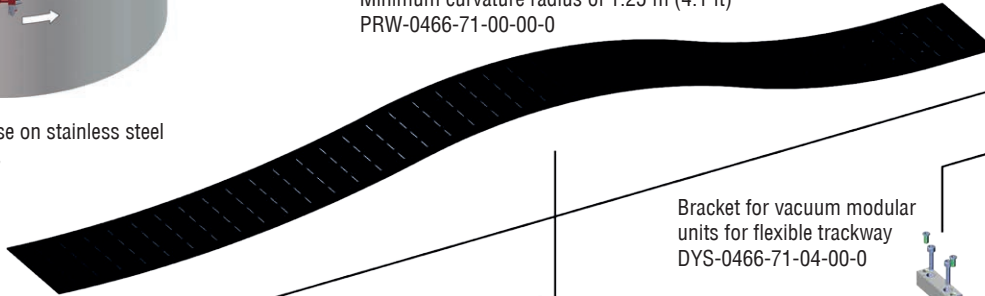

Bracket for
magnetic
units for flexible
trackway
DYS-0466-71-05-00-0

Bracket for magnetic narrow
unit for flexible trackway
DYS-0466-71-07-00-0

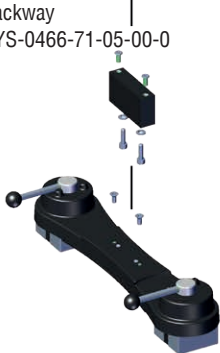

Magnetic narrow unit
with hexagon
PDS-0582-10-00-02-0

Magnetic unit
ZSP-0475-44-00-00-0



Steel track support
for flexible trackway
WSP-0466-71-06-00-0

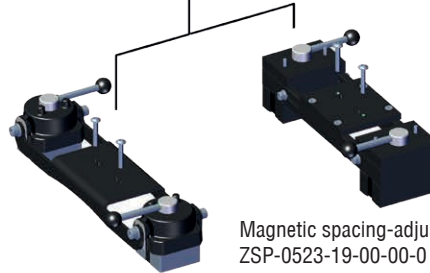

Magnetic spacing-adjustable unit
ZSP-0523-19-00-00-0

Magnetic pivoting unit
ZSP-0475-85-00-00-0



ZST-0466-69-00-00-0
Trackway following guide
arms (set of 2 pcs)

Bracket for vacuum modular
units for flexible trackway
DYS-0466-71-04-00-0

Bracket for magnetic
units for flexible trackway
DYS-0466-71-05-00-0

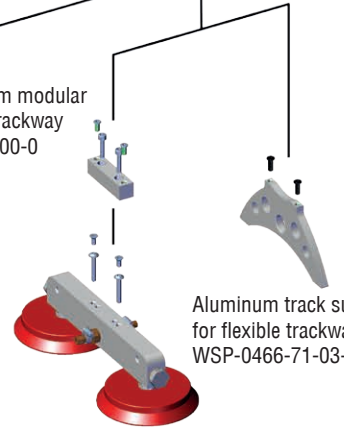

Aluminum track support
for flexible trackway
WSP-0466-71-03-00-0

Vacuum modular unit
MST-0541-10-02-00-0



More
information about
Promotech's Vacuum
System configurations and
components is available
at company website
www.promotech.eu

More information at www.promotech.eu

Mitglied im **DVS**
DVS – Deutscher Verband für Schweißen
und verwandte Verfahren e.V.



American Welding Society

Supporting Company Member

Your local dealer:



PROMOTECH Sp. z o.o.
ul. Elewatorska 23/1, 15-620 BIAŁYSTOK, POLAND
tel. (+48 85) 678 34 05, fax (+48 85) 662 78 77
marketing@promotech.eu www.promotech.eu

All information is subject to change without notice. 1612